

Extend gear coupling life

Extended service of gear couplings can be achieved by understanding the principles of wear, how lubricants function and proper maintenance

Michael M. Calistrat, Koppers Co., Inc.
Baltimore, Md.

PROPER LUBRICANT selection greatly increases the life of gear couplings. Once properly installed periodic lubrication is the only maintenance required. In order to select proper lubricants the principles of gear wear and lubricant properties must be understood.

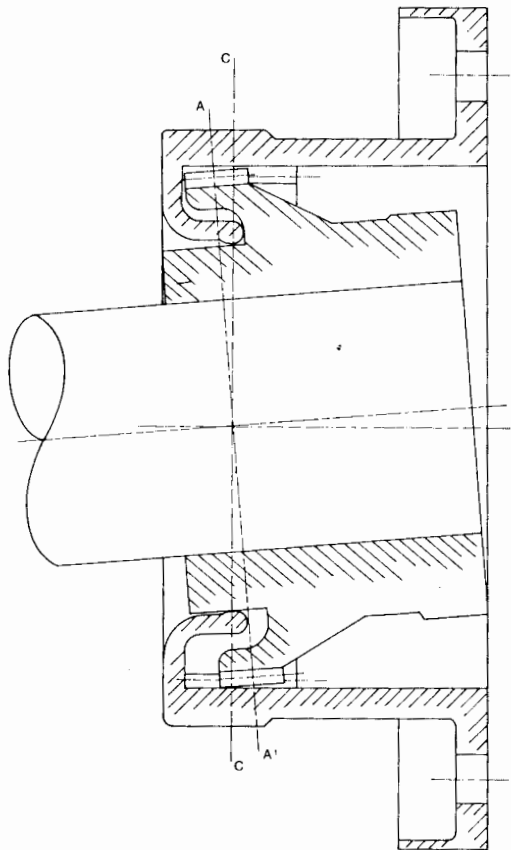

Fig. 1—Misaligned gear coupling.

Since maintenance is a disadvantage of gear couplings compared with “dry” couplings, why are they so popular? The principal reasons are: Gear couplings can transmit more power per pound, and per inch of diameter than any other type of coupling; Gear couplings are forgiving; even when improperly installed, or mishandled, they continue to perform better than most other types of couplings; gear couplings are reliable and safe. Their main cause of failure is teeth wear, which is gradual rather than abrupt. Even when the teeth wear out completely the only effect is loss of power without the coupling flying apart.

Couplings in general can be divided into low speed, or standard couplings, and high speed, or high performance couplings. Maintenance requirements of the two types are very different. This article will describe maintenance of the standard type.

Standard couplings can be defined as the ones “off the shelf,” not made to order. They generally operate at “motor speeds” and are seldom dynamically balanced. The gear coupling was invented by Gustave Fast of Baltimore, Md. in 1920. His basic design is still used today. Many of the original dimensions for sleeve flanges and bolt sizes became standards of the industry. As a consequence, couplings made today by any manufacturer can be bolted, by half-coupling, with other manufacturer’s couplings. Standard couplings are sized for the nominal shaft diameter in ½-inch increments. A size 1½ (or 15 in some cases) is designed to accept a 1.5 in. shaft, however most hubs can be overbored as much as ½-in. The size of a coupling also represents, with few exceptions, the pitch radius of the gear mesh.

Why do gear couplings require lubrication? Although standard couplings are made in a large variety of constructions, they can be divided into two categories depending on the method used to accommodate misalignment: through flexing or through sliding. Gear couplings fall into the second category. Fig. 1 shows a section of a gear coupling in which the misalignment is intentionally exaggerated. Let us follow the path of the hub tooth “A” as the coupling makes one revolution. Without misalignment the tooth will stay in the plane C-C. Because of the misalignment the tooth is to the left of the plane C-C in the upper position, but after one half revolution it moves to the right of plane C-C in the position marked A¹. After the coupling completes the

revolution the tooth assumes again the position A. Although the hub tooth remains constantly engaged with the same sleeve tooth, it moves back and forth over the surface of the mating tooth. The frequency of this oscillatory motion is the same as the shaft's speed. The amplitude of the motion (i.e. the total travel of the hub tooth from one extreme to the other) is very small and is a function of the pitch diameter and the angle of misalignment:

$$a = \text{P.D.} (\tan \alpha) \quad (1)$$

The velocity of the oscillatory motion is a function of the amplitude and of the shaft rpm.

$$V_s = \frac{\pi N}{60} (a) = \frac{\pi (N) \text{P.D.}}{60} (\tan \alpha) \quad (2)$$

To prevent the wear that this rubbing of one tooth against the other generates, gear couplings must be lubricated.

How does the lubricant work? The forces between the mating teeth as well as the oscillatory motion tend to wipe off the lubricant from the contact surfaces. However, when one tooth slides in one direction the lubricant has a chance to wet the area left uncovered behind the tooth. To do that the lubricant has to work against two elements: its own viscosity, and the very short time available during one cycle. The teeth would operate dry if it wasn't for the high centrifugal forces created by the couplings' rotational speed. This forces the lubricant between the teeth insuring good lubrication.

It is customary to measure the effect of centrifugal forces with a factor G which indicates the apparent increase in an object's weight when the object rotates around an axis.

$$G = 28.4 (10^6) R N^2 \quad (3)$$

inside a coupling we can write

$$G = 14.2 (10^6) (\text{P.D.}) N^2 \quad (4)$$

The graph from Fig. 2 helps in finding the G level in couplings. For example, a Size 4 coupling, with an 8-in. pitch diameter, operating at 3,500 rpm has a G of 1,390 or, as it is common to say, has 1,390 G 's. This large apparent increase in weight forces the lubricant to flow rapidly and replenish the voids left behind by the moving teeth. The influence of centrifugal forces on the quality of lubrication was confirmed in lab tests. As Fig. 3 shows, the wear rate of a coupling decreases rapidly as the speed increases up to a point where no further benefit is obtained from an increase in the G level.

Oil versus grease—which is better? To compare oils with greases we have to look at two of their features: lubrication properties and convenience. One must first understand that greases are nothing but oils to which a thickening agent was added. The vast majority of greases (about 97 percent of total U.S. production) use a metallic soap as the thickening agent. Generally, these soaps have no lubricating properties, hence a grease is no better than the oil used in blending it. The biggest advantage of greases is that they are easier to seal, thus they stay where the lubricant is needed.

Figs. 4 and 5 illustrate two of the most popular type

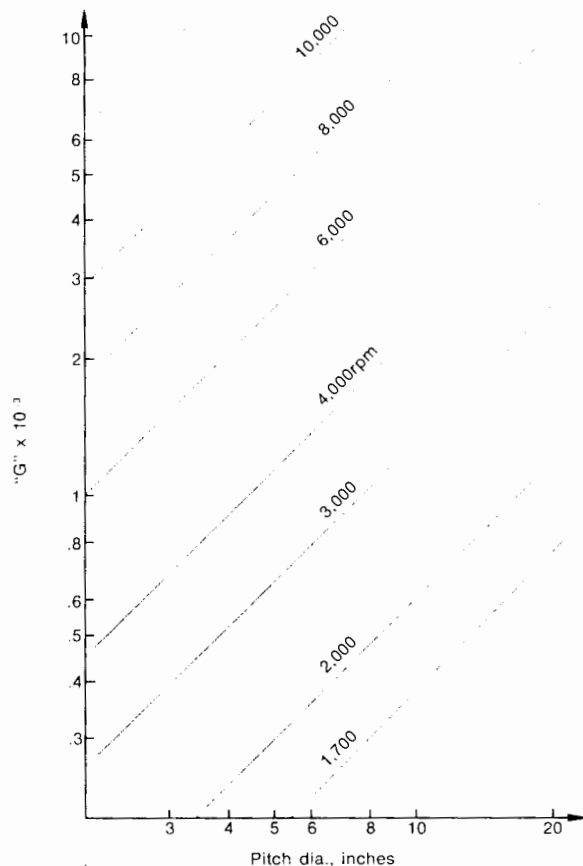

Fig. 2—Centrifugal forces in couplings.

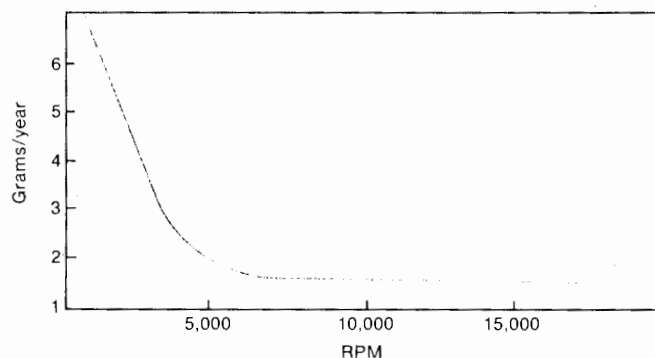

Fig. 3—Gear coupling wear rates as a function of speed.

of gear couplings; the Fast type, with an all metal seal, and the elastomer seal type. When the couplings rotate, centrifugal forces cause the lubricant to form an annulus inside the sleeve. The inside diameter of the lubricant annulus is always the seal diameter because none of the coupling seals can retain more lubricant when under high G 's. The seal of the Fast type is one of the few so designed that, under static condition it will retain enough oil to form an adequate annulus when the coupling is rotating.

Oils cannot be used with elastomer seal couplings (Fig. 5) mainly because they cannot retain enough lubricant under static conditions. Either oil or greases can be used in Fast type couplings. The question of which is better applies only to the Fast couplings. The answer depends on whether a good grease is available. If it is, then a grease is preferable simply because more lubricant

EXTEND GEAR COUPLING LIFE

can be packed in the coupling, even though a small part of the lubricant is a thickener. If a good grease is not available, then any high viscosity oil is preferable. Why high viscosity? Studies performed in the lab with standard couplings indicated that the most influential parameter for coupling wear is the oil viscosity. The graph (Fig. 6) shows that the higher the oil viscosity, the smaller the wear-rate. When greases are considered the consistency of the grease should not be confused with the viscosity of the base oil. The same grease consistency can be obtained with a wide variety of oils of different viscosities.

Greases and centrifugal forces. Let us first see what happens when the centrifugal force is very small, which can be the case either at low speeds or when small couplings are used. Because the grease is subjected to a small centrifugal force it needs more time to flow into the voids between the teeth. Fortunately, at lower speeds more time is available. While the time available in-

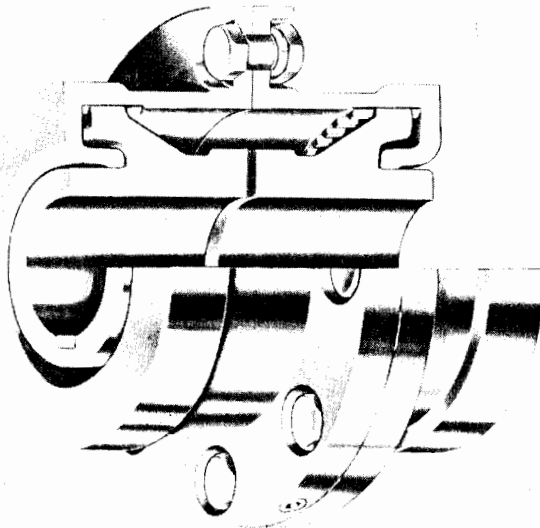

Fig. 4—All metal seal coupling.

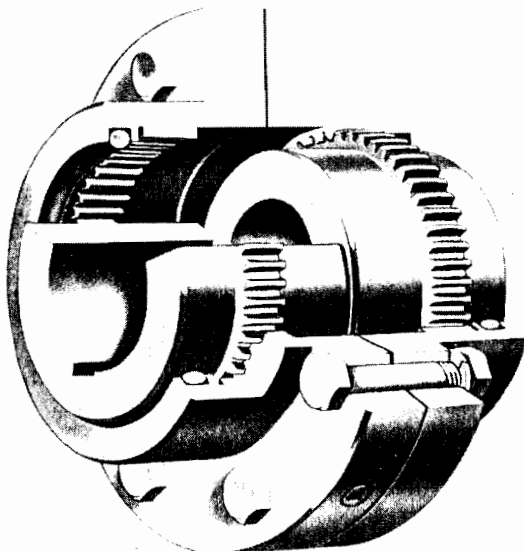

Fig. 5—Elastomer seal coupling.

creases in the same ratio that the speed decreases, the centrifugal forces decrease with the square of the speed, as shown in Equation 4. Thus, the forces that make the grease flow decrease more rapidly than the time available increases. At some speeds the coupling could operate without sufficient lubrication, even when it is full of grease. This condition becomes particularly critical when stiff greases (NGLT No. 2 or No. 3) are used, because they flow less readily than a No. 1 or No. 0 grease. It was determined experimentally that a No. 2 (or stiffer) grease should not be used when the coupling operates below 10 G's, i.e. when the speed is below:

$$N_c = 850 \sqrt{(P.D.)} \quad (\text{Remember: P.D. is approximately twice the coupling size}) \quad (5)$$

Now let us see what happens under normal operating conditions. It is known that greases have a tendency to partially lose their oils, a phenomenon known as "bleeding." There are three primary forces responsible for oil separation from greases³: syneresis, gravity and external pressures. In couplings the apparent gravity generated by centrifugal forces is so high that the other forces responsible for bleeding become insignificant.

Centrifugal forces have a larger effect on thickeners from the grease than on the oils because thickeners have a higher specific gravity. Hence, the thickeners are forced away from the axis of rotation, and will eventually coat the inside surface of the coupling sleeves. In observing Figs. 4 and 5 one can see that the gear mesh (the hub and sleeve teeth) is located on the sleeve's inside diameter.

Hence, the soap separated from the grease will surround the coupling's teeth and *WILL PREVENT THE OIL FROM LUBRICATING THE TEETH SURFACES*. In other words, although the coupling is full of grease it can be starved of lubricant. Understanding this phenomenon is very important for proper coupling maintenance.

For many years it was assumed that the amount of oil separation was a function of the G level only. Consequently, some greases that were not acceptable for high speed operations were considered acceptable for standard couplings. Recent studies^{4,5} have shown that rather than being a function of the G level, the maximum oil separation from a grease is mainly a function of time. This means that a grease will bleed a given percentage of oil at any G level, if it is subjected to these centrifugal forces for a long enough period of time. We use a standard test method⁴ for evaluating greases: a sample is subjected to a high centrifugal force (36,000 G's) in a laboratory centrifuge, and the oil separation is closely monitored. The test is interrupted when the separation stabilizes. The greases are then given a (K36) rating which is a fraction. The numerator represents the maximum oil separation in volumetric percentage, and the denominator represents the time required to attain that separation. For example, if a grease has $K36 = 70/35$ it has a maximum oil separation of 70 percent and it needs 35 hours of operation at 36,000 G's to attain this separation. When the grease is subjected to a smaller centrifugal force, the time required for the maximum separation can be calculated with the experimental formula:

$$t = 2,400,000 T/G^{1.4} \quad (6)$$

where T is the number of hours used to determine the K36 factor.

Which grease is best? Coupling manufacturers rely both on lab tests and field experience when making grease recommendations. Depending on the application some greases are better than others. Just because a particular grease is not on a list of recommended lubricants does not necessarily mean that it is not suitable.

There are four basic parameters that can be used for evaluating greases for gear couplings:

A grease should have more than 92 percent oil. It was shown that most greases will eventually separate into oil and soap. The more soap a grease has, the higher the chances of the teeth being starved of lubricant. The 92 percent level is a desirable number rather than an excluding one, but it is not unrealistic; there are many greases that have more than 92 percent oil.

A grease should have a base oil with a high viscosity. It was shown (Fig. 6) that the higher the viscosity of the oil, the lower the wear-rate of the coupling. Oil viscosity should not be confused with the grease's consistency. To blend a given grease, let's say a NLG1 No. 1, oils with viscosities as low as 200 or as high as 4,000 SSU at 100° F can be used. If the oil is lighter more thickener is used in order to attain the desired grease consistency. An oil viscosity higher than 900 SSU at 100° F is desirable.

A grease should resist centrifugal separation. Very few companies are equipped to determine this characteristic, however K36 values are available for many greases. For a good choice a grease should not only bleed as little oil as possible, but should also bleed the oil slowly.

A gear coupling grease should not have a consistency higher than NLG1 No. 1. It was shown that a more consistent grease could cause problems at low G 's. In order to avoid misapplications one should not use No. 2 or No. 3 greases.

Some good quality greases incorporate special additives or fillers. Experience has shown that EP additives are beneficial only in highly loaded couplings, and in all couplings during the breaking-in period. Under normal conditions couplings do not operate under high contact pressure. Lead, molybdenum disulfide and other high density compounds will separate immediately inside the coupling, and as such are beneficial only in very low speed, high load applications.

Coupling's breaking-in. Usually the gear mesh of a coupling has 60 teeth at the hub and as many at the sleeve. The number can vary slightly depending on the coupling's size. Because of the many teeth, and depending on the precision of manufacture, more or less of the matching teeth will be in contact when the coupling first starts transmitting the torque, even if the coupling is perfectly aligned. The teeth that do transmit the torque are subjected to larger than normal forces, so they wear relatively fast. However, as these teeth wear, the other teeth that originally were not in contact start sharing the load. Eventually all the teeth are in contact and the coupling is broken-in. The duration of the breaking-in depends on the load, the quality of manufacturing and the materials used. Experience and laboratory tests show that a standard

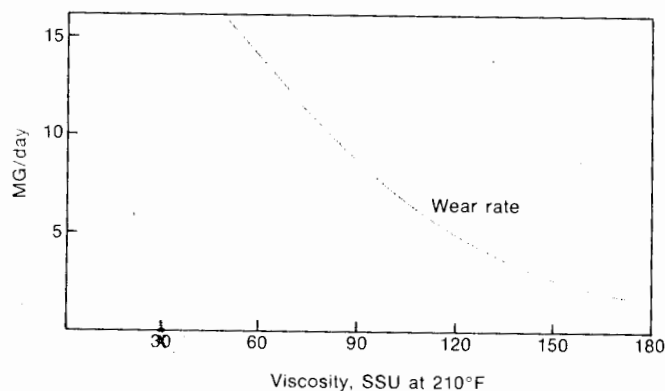

Fig. 6—Effect of lubricant viscosity on coupling wear.

gear coupling is completely broken-in in three to five days.

Breaking-in of a coupling creates a special problem for the lubricant: high temperatures. Rapid wear of the teeth that are originally in contact generates heat at a larger rate than the coupling can normally dissipate. Temperature at the surface of the sleeve can reach as much as 120° F above ambient. If the ambient temperature is high the grease in the coupling could operate close to, or even above its dropping point. For this reason greases with a low dropping point should be avoided. It is also possible that during breaking-in the flange bolts will lose some of their pretorque. If the equipment can be stopped approximately a week after start-up the coupling should be inspected and the bolts retightened. Unless there is evidence of grease loss between the flanges there is no need for relubrication at that time.

Maintenance procedure. In the order of increasing complexity, maintenance can consist of: relubrication, relubrication with realignment and coupling replacement.

Even the best coupling greases cannot perform too long; besides the inevitable soap separation, oils oxidize and lose some of their lubricating properties. The possible loss of lubricant should also be considered. Many users do not install the paper gasket or O-ring between the flanges, which is a mistake. Manufacturers recommend relubrication at either six months or every year. Actually, depending on the grease used and the G level in the coupling, relubrication periods could be longer, or shorter. Independent of how often the coupling is lubricated, it should first be opened and as much of the old grease as possible should be removed. Even if cleaning is sometimes difficult it should be done because it prolongs coupling life and prevents unscheduled equipment breakdown.

Here are a few rules to be observed when opening a coupling: Remove and save the bolts and nuts. In most cases the bolts have special body tolerances and should not be replaced with "similar" bolts. Lock-nuts should be replaced after six installations, or when they are loose on the bolts. Do not separate the sleeves by forcing a chisel or screwdriver between the flanges. By damaging the flange surfaces a good seal can no longer be made and one risks losing the lubricant when the coupling is re-started. Remove as much of the old grease as possible.

When reassembling the coupling use a new gasket if the old one is damaged. Proper bolt torqueing is very important not only to form a good seal at the flanges, but also for proper torque transmission. One should keep in mind that in a properly installed coupling the torque is

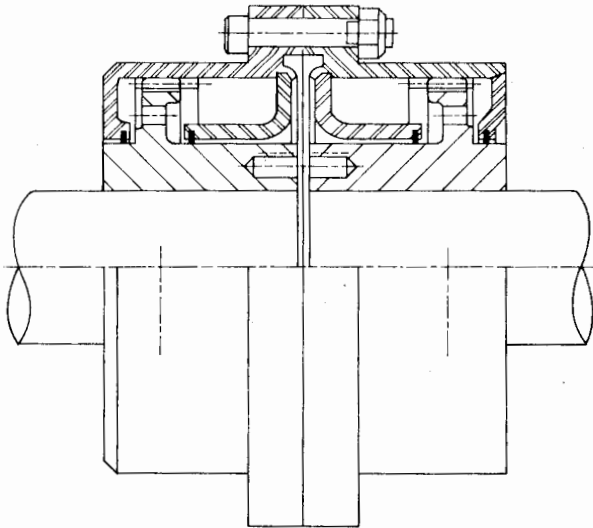

Fig. 7 — Permanently sealed gear coupling.

transmitted from one flange to the other mainly through friction; only a small part of the torque is transmitted through the bolts. If the bolts are not properly tightened then they are subjected to shear forces that can damage the bolts and elongate the flange holes. Bolt torquing values are available from coupling and fastener manufacturers and depend on coupling size, type and manufacturer.

The lubricant capacity can vary anywhere from a few ounces to over 25 lbs. In order not to waste lubricant the manufacturer's recommendations should be followed. If this information is not readily available it is safe to remove two opposite lube plugs, rotate the coupling until the lube holes are about 45 degrees to the vertical, and pump lubricant through the upper hole until it comes out through the bottom one. In no case should grease be pumped into a coupling if a second lube plug was not removed. The pressure developed by a grease gun is very high and a closed coupling can be damaged. If the coupling is new, or if an old coupling was completely cleaned of the old grease, it is very important to hand pack the teeth with some lubricant to insure proper coupling performance at start-up. There is no danger in overfilling a coupling with lubricant!



About the author

MICHAEL M. CALISTRAT is manager, Power Transmission Development Sections, Research and Development Department, Koppers Co., Inc., Baltimore, Md. In this capacity, he is responsible for improving the existing product line and developing new flexible coupling products. Mr. Calistrat graduated from the University of Bucharest with an M.S. degree in mechanical engineering. He is currently chairman of the Shaft

Coupling and Clutches Subcommittee of ASME. Mr. Calistrat holds 14 patents and has authored and presented a number of technical papers.

If a long spacer is used between the sleeves, and if the spacer is not provided with plates at both ends, a full disk gasket and back-up metal plate should be used between each sleeve and the spacer. The gasket should be installed between the sleeve and back-up plate rather than the other way. Without a back-up plate the disk gasket will most likely be ruptured by the pressure developed by the centrifugal forces. When spacers are used it is important that each half-coupling be lubricated individually.

At least at the first maintenance stop the original alignment should be checked to verify if either machine moved on its base. Many good articles, and good instructions on alignment are available.

If the coupling must be removed, but will be reused, the hub should not be pulled by the sleeve as permanent damage at the sleeve could occur. If the hub does not have puller holes a plate that does not touch the sleeve should be used behind the hub.

Many questions have been asked about the use of heat for hub removal. Heat is beneficial only if the hub can be heated faster than the shaft, which is seldom the case. A welding torch will most likely damage both the coupling and the shaft. To avoid difficulties in hub removal the best procedure is to use an anti-seize compound on the shaft when the hub is first installed. If an anti-seize compound is not available, a grease with a zinc-oxide filler can be used successfully.

A maintenance free gear coupling. In some applications the equipment to which a coupling is installed cannot be stopped when relubrication is scheduled. While this causes no problems in lubricating the equipment's bearings, it prevents coupling lubrication. It is then possible that the coupling is not serviced until the next scheduled maintenance, or the next one, or never.

A coupling⁶ which incorporates the advantages of a gear coupling, but does not require periodic maintenance is shown in Fig. 7.

Each half-coupling is double sealed; the lubricant will not be lost or contaminated when the two flanges are separated.

The coupling has a larger lubricant capacity than the Fast's and does not require relubrication for a period generally longer than the one of the connected machinery. A few prototypes have been in continuous and successful operation in selected petrochemical plants for about three years.

NOMENCLATURE

- a = amplitude of axial motion, inches
- P.D. = pitch diameter of the gear mesh, inches
- α = angle of misalignment, degrees
- V_s = axial sliding velocity, inches/second
- N = rotational speed, rpm
- R = radius of rotation around an axis, inches
- N_c = critical speed for some greases, rpm
- t = time required for centrifugal separation, hours

LITERATURE CITED

- ¹ Wright, John, "Which shaft coupling is best . . . lubricated or non-lubricated?" *Hydrocarbon Processing*, April 1975.
- ² Calistrat, Michael, "What causes wear in gear-type couplings?" *Hydrocarbon Processing*, January 1975.
- ³ Calhoun, S. F., "Fundamental Aspects of Grease Bleeding." NLGI Spokesman, January 1966.
- ⁴ Calistrat, Michael, "Grease Separation Under Centrifugal Forces." ASME Paper No. 75-PTG-3, ASME-ASLE Lubrication Conference, October 1975.
- ⁵ Clapp, A. M., "Fundamentals of Lubrication Relating to Operation and Maintenance of Turbomachinery," First Turbomachinery Symposium, Texas A & M University, October 1972.
- ⁶ U.S. Patent No. 3,953,986, May 1976.